

# ELEVAR BACK TO BACK

## SPECIFICATIONS

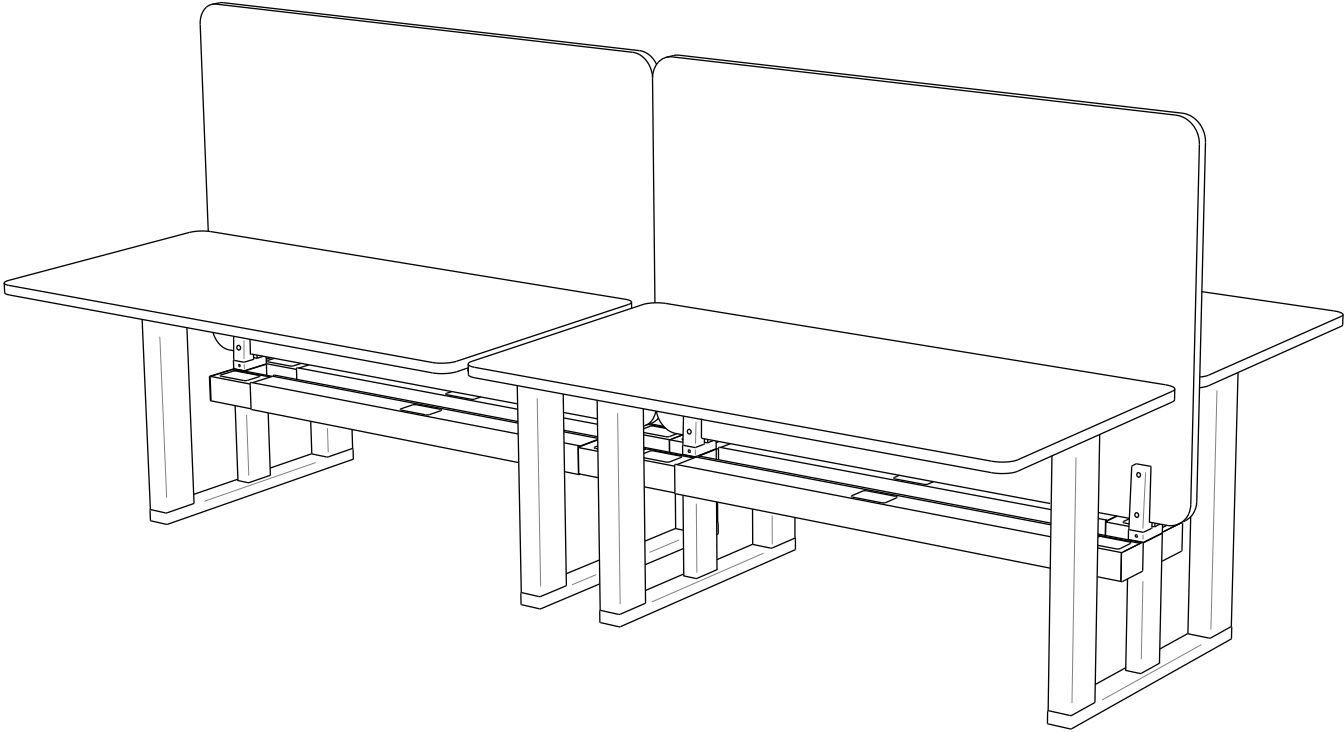

**ADJUSTABLE FRAME SIZES**

DEPTH 600mm - 900mm  
WIDTH 1200mm - 2000mm

**ADJUSTABLE CABLE GUTTER**

WIDTH 1200mm - 2000mm

**ADJUSTABLE SCREEN BRACKETS**

SUIT ACOUSTIC/SOLID CORE AND ALUMINIUM FRAME

**ELECTRIC ADJUSTABLE FEATURES**

- IMPACT SAFETY Automatic Collision Control
- SHELF STOP Programmable Safe Range
- OVERHEAT SAFETY Automatic Overheat Cut-off Switch
- 2 BUTTON UP/DOWN HANDSET 2 and 3 Stage Electric
- 3 BUTTON PROGRAMMABLE HANDSET 3 Stage Electric

**POWDERCOAT FINISHES**

- Gloss White (Short lead time)
- Satin Black (Short lead time)
- Silver and other finishes available as a custom/project order

**WARRANTY**

10 Years All Components

**AFRDI CERTIFICATION**

Cert No 12425/1 (3 Stage Electric Only)

**CONFIGURATIONS**

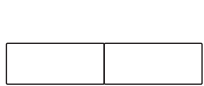

SIDE BY SIDE



BACK TO BACK

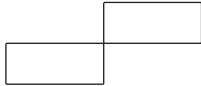

STAGGERED



CLUSTER

# ELEVAR BACK TO BACK

## SPECIFICATIONS

### LEG OPTIONS

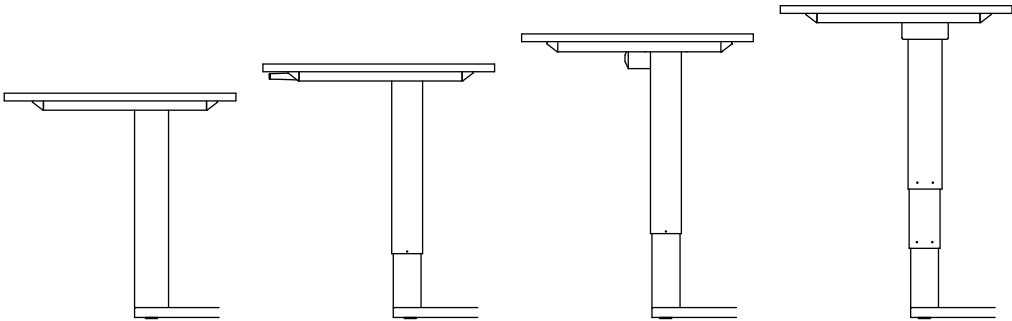

**Fixed Height**      **2 Stage Fast Crank**      **2 Stage Electric**      **3 Stage Electric**

<b>HEIGHT RANGE</b>	720mm W/ 25mm TOP	660mm-1110mm W/ 25mm TOP	700mm-1200mm W/ 25mm TOP	650mm-1300mm W/ 25mm TOP
<b>LOAD CAPACITY</b>	120kg	100kg STATIC 50kg DYNAMIC	80kg	120kg

### SCREENS

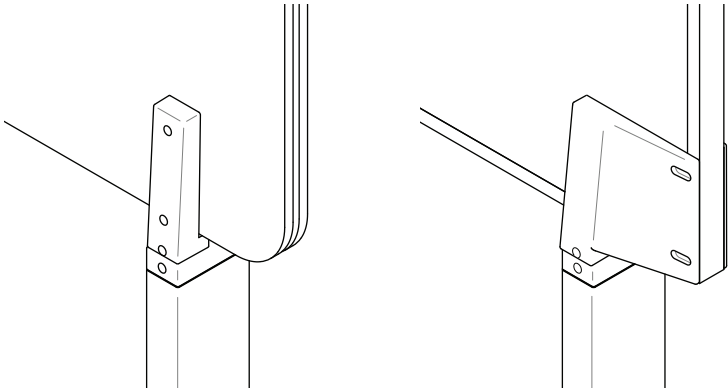

**ACOUSTIC/SOLID CORE**  
Adjustable size to suit screens  
20mm to 60mm thickness

**ALUMINIUM FRAME**  
Adjustable size to suit screens  
20mm to 60mm thickness

### SYSTEM DIMENSIONS

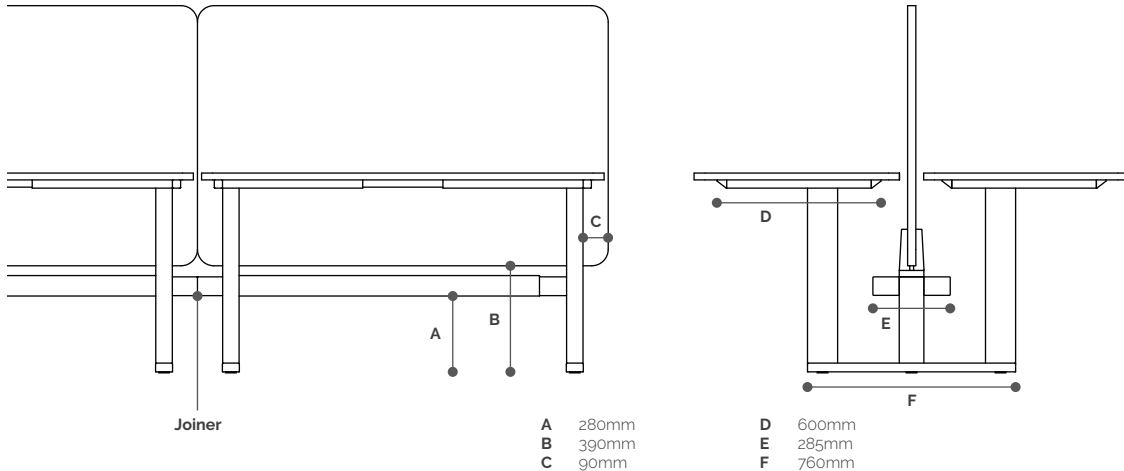

### CABLE GUTTER

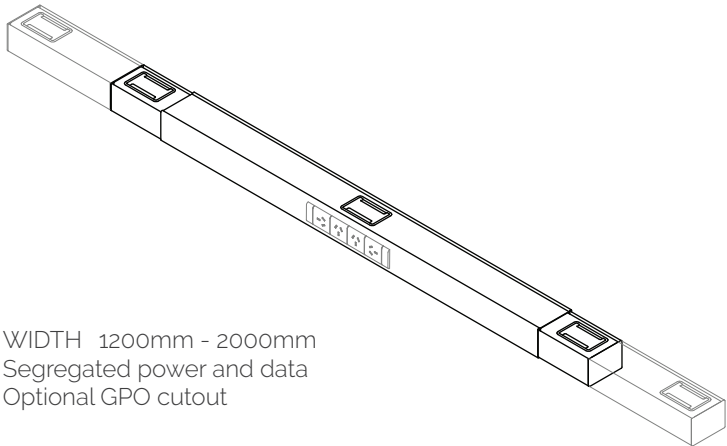

**WIDTH** 1200mm - 2000mm  
Segregated power and data  
Optional GPO cutout